

# Super Conducting Quantum computer

## Abstract

Superconducting qubit calculations .

## Index Terms

Superconducting, qubit, quantum computer

## CONTENTS

<b>I</b>	<b>Introduction</b>	1
<b>II</b>	<b>Unbiased Josephson Junction</b>	2
<b>III</b>	<b>Biased Josephson Junction: Current Voltage Characteristics</b>	2
<b>IV</b>	<b>Josephson-Junction Qubits</b>	3

## I. INTRODUCTION

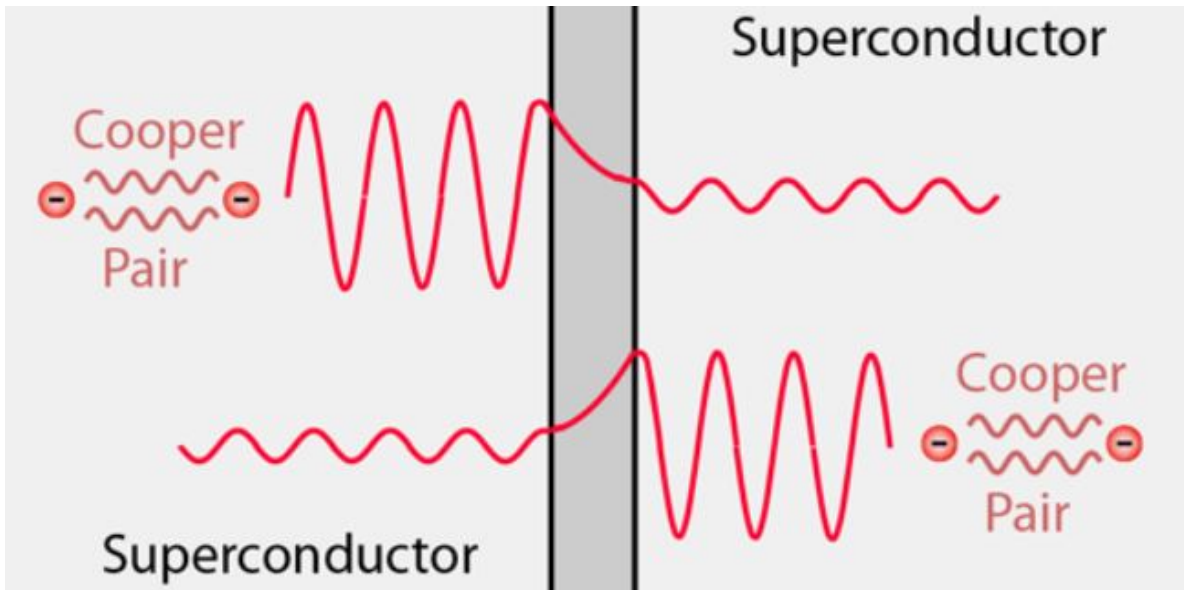

Figure 1: Illustration of Josephson Junction

Super Conducting qubit is a Josephson Junction (JJ) which is composed of two superconducting metals separated by a thin insulator. The current through a JJ is carried by tunneling Cooper pairs. JJ can be described in the Ginzburg-Landau (GL) approximation. Quantum state of the system can be described by wavefunctions

$$\psi_i = \sqrt{n_i} e^{i\phi_i}, \quad (1)$$

where  $i = 1, 2$  labels the left and the right regions. In GL model the electron number density of Cooper pairs ( $2e$  charge) in the  $i^{th}$  region is given by  $n_i = |\psi_i|^2$ , and the current is given by  $i = 2e\dot{n}$  where  $n = n_2 - n_1$ . We can assume that  $n_1 \approx n_2 \approx n_0/2$ . However we will carefully keep track of the difference  $n$ . We will first consider the junction with no bias voltage.

email: [quarktetra@gmail.com](mailto:quarktetra@gmail.com)

Find the interactive HTML-document here.

## II. UNBIASED JOSEPHSON JUNCTION

Although there is no external voltage applied, there will be a voltage difference between the two regions if  $n \neq 0$ . This potential difference between the regions is  $\Delta V = -ne/C$ , where  $C$  is the capacitance of the junction. Hence, the energy difference is  $\Delta U = 2e\Delta V = -2ne^2/C$ . We can now write the Schrodinger equations for the wave functions  $\psi_1$  and  $\psi_2$  as

$$\begin{aligned} i\frac{d\psi_1}{dt} &= U\psi_1 - \frac{E_J}{n_0}\psi_2, \\ i\frac{d\psi_2}{dt} &= (U + \Delta U)\psi_2 - \frac{E_J}{n_0}\psi_1, \end{aligned} \quad (2)$$

where  $E_J$  is the so called Josephson Energy. Using  $\psi_i = \sqrt{n_i}e^{i\phi_i}$  and multiplying the first (second) line by  $\psi_1$  ( $\psi_2$ ), we get

$$\begin{aligned} i\frac{\dot{n}_1}{2} - n_1\dot{\phi}_1 &= Un_1 - \frac{E_J}{n_0}\sqrt{n_1n_2}e^{i\phi} \\ i\frac{\dot{n}_2}{2} - n_2\dot{\phi}_2 &= (U + \Delta U)n_2 - \frac{E_J}{n_0}\sqrt{n_1n_2}e^{-i\phi}, \end{aligned} \quad (3)$$

where we defined  $\phi = \phi_2 - \phi_1$ . Taking the imaginary part of the difference of two lines we get

$$\dot{n}_2 - \dot{n}_1 = \dot{n} = \frac{2E_J}{n_0}\sqrt{n_1n_2}\sin\phi \simeq E_J\sin\phi, \quad (4)$$

from which we can easily get the current as

$$i = -2e\dot{n} = -2eE_J\sin\phi. \quad (5)$$

In Eq. (3), dividing the first (second) line by  $n_1$  ( $n_2$ ) and taking the real part of the difference we get

$$\dot{\phi}_2 - \dot{\phi}_1 = \dot{\phi} = -\Delta U - \frac{E_J}{n_0}\left(\sqrt{\frac{n_2}{n_1}} - \sqrt{\frac{n_1}{n_2}}\right)\cos\phi \simeq \frac{2ne^2}{C}, \quad (6)$$

where we ignored a term with the square roots since it is of second order in  $n$ . Eqs. (4) and (6) are coupled differential equations, and we decouple them by substituting Eq. (4) in the derivative of Eq. (6) to get

$$\ddot{\phi} = -\frac{2e^2E_J}{C}\sin\phi \simeq -\frac{2e^2E_J}{C}\phi, \quad (7)$$

which is an harmonic oscillator with frequency  $\omega_J = \sqrt{\frac{2e^2E_J}{C}}$ . Note that we assumed  $E_J > 0$ , therefore the oscillations are around  $\phi = 0$ . If  $E_J < 0$ , the oscillations will be around  $\phi = \pi$ .

## III. BIASED JOSEPHSON JUNCTION: CURRENT VOLTAGE CHARACTERISTICS

If the junction is connected to a voltage source, the energy difference is  $\Delta U = 2eV$ , where  $V$  is the applied voltage. We just need to modify Eq. (6),

$$\dot{\phi} \simeq -\Delta U = -2eV, \quad (8)$$

which can be solved immediately to yield

$$\phi(t) = \phi_0 - 2eVt. \quad (9)$$

Putting this back into Eq. (5) yields

$$i(t) = -2eE_J\sin\phi = -2eE_J\sin(\phi_0 - 2eVt). \quad (10)$$

This equation shows the unusual behavior of the Josephson junction: the current is sinusoidal when the voltage is constant! These are the two important equations in this sub-chapter:

$$\begin{aligned} i(t) &= I_c\sin\phi \\ \frac{d\phi}{dt} &= -2eV. \end{aligned} \quad (11)$$

However, we still need to calculate the Hamiltonian, since it governs the quantum dynamics of the system. For later convenience, let us assume that the independent variable is the current and we want to eliminate voltage in favor of it. Let us also assume that we drive the system by an external current,  $i_e$ . The Hamiltonian consists of two parts, the stored electrostatic energy and the work done by the current on the junction, that is

$$\begin{aligned} H &= \frac{\hat{Q}^2}{2C} - \int dt I(t)v(t) = \frac{\hat{Q}^2}{2C} + \frac{1}{2e} \int dt (I_c \sin \phi - i_e) \frac{d\phi}{dt} \\ &= \frac{\hat{Q}^2}{2C} - \frac{I_c}{2e} \cos \phi - \frac{i_e \phi}{2e}. \end{aligned} \quad (12)$$

Comparing this Hamiltonian with the usual Hamiltonian with  $p$  and  $x$ , we see that  $\hat{Q}$ ,  $\phi$  and  $C$  play the role of  $\hat{p}$ ,  $x$  and  $m$ , respectively.

#### IV. JOSEPHSON-JUNCTION QUBITS

We will start with the Hamiltonian in Eq. (12)

$$H = \frac{\hat{Q}^2}{2C} - \frac{I_c \Phi_0}{2\pi} \cos \hat{\delta} - \frac{I \Phi_0}{2\pi} \hat{\delta}, \quad (13)$$

where we defined  $\Phi_0 = h/2e$ . Note that the potential in the Hamiltonian is

$$U = -\frac{I_c \Phi_0}{2\pi} \left( \cos \hat{\delta} - \frac{I}{I_c} \hat{\delta} \right). \quad (14)$$

Taking the derivative shows that the potential has a minimum if  $\frac{I}{I_c} < 0$ . In the figure we plot the potential for  $\frac{I}{I_c} = 0.98$ .

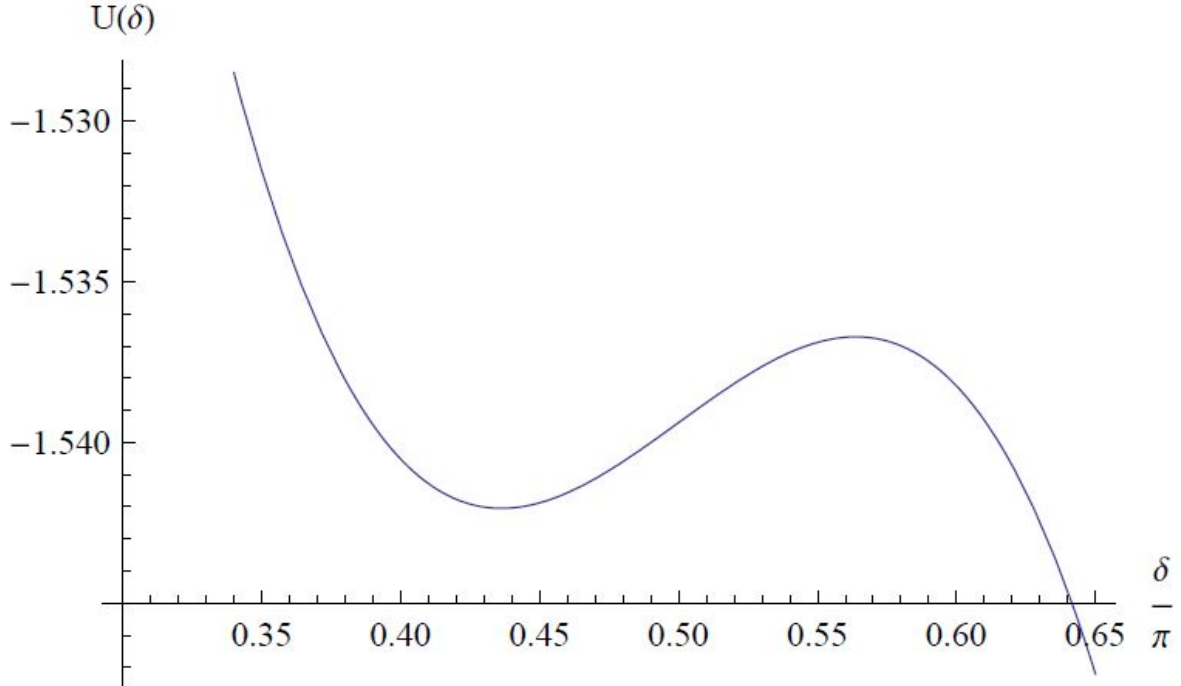

Figure 2: The potential for the biased Josephson junction.

The high of the barrier becomes zero if  $\frac{I}{I_c} = 1$ . Therefore, since we can control  $I$ , we can control the height of the barrier. If we choose it appropriately, this potential can support two and only two states, as shown in the figure.

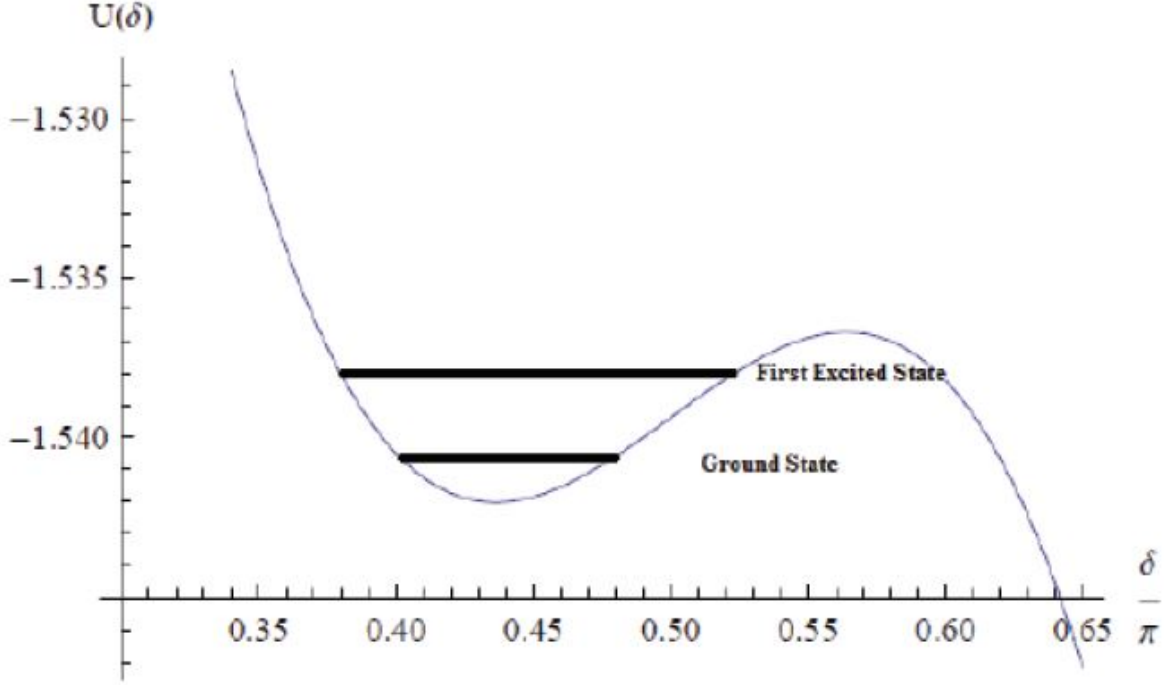

Figure 3: The energy levels for the biased Josephson junction.

Let us now decompose the control current into two parts,

$$I(t) = I_{dc} + I_{rf} \cos(w_{rf}t + \varphi), \quad (15)$$

where  $I_{rf} \ll I_{dc}$ .  $I_{dc}$  is chosen such that the potential supports two states. The  $I_{rf}$  part can be treated as a perturbation over the background. The perturbation Hamiltonian can be written as

$$\begin{aligned} H_2 &= -\frac{I_{rf}\Phi_0}{2\pi} \cos(w_{rf}t + \varphi) \begin{pmatrix} \langle 0|\hat{\delta}|0\rangle & \langle 0|\hat{\delta}|1\rangle \\ \langle 1|\hat{\delta}|0\rangle & \langle 1|\hat{\delta}|1\rangle \end{pmatrix} \\ &= -\Delta \cos(w_{rf}t + \varphi) \sigma_x. \end{aligned} \quad (16)$$

$|0\rangle$  and  $|1\rangle$  are the ground and the first excited states of the system, which can be approximated by the usual harmonic oscillator states. The diagonal terms vanish due to parity. Now if we choose our reference energy level at the middle of the two energy levels the full Hamiltonian can be written as

$$H = \frac{w_0}{2} \sigma_z - \Delta \cos(w_{rf}t + \varphi) \sigma_x, \quad (17)$$

where  $w_0$  is the energy difference between the levels. This Hamiltonian is the same as the one we considered for the NRM QC and we have shown in that it can generate any rotations in the Bloch Sphere.

**Measurement:** Measurement in this setup is very simple. By increasing  $I_{dc}$  we can lower the height of the barrier to a value between the energy levels. Assume the state is the first excited one. In this case, the state will have enough energy to go over the barrier, and it can be measured by a sensor. If the state is the ground one, it will still stay in the barrier.

**Coupling:** Coupling for the model at hand can be done by capacitors as shown in the figure below.

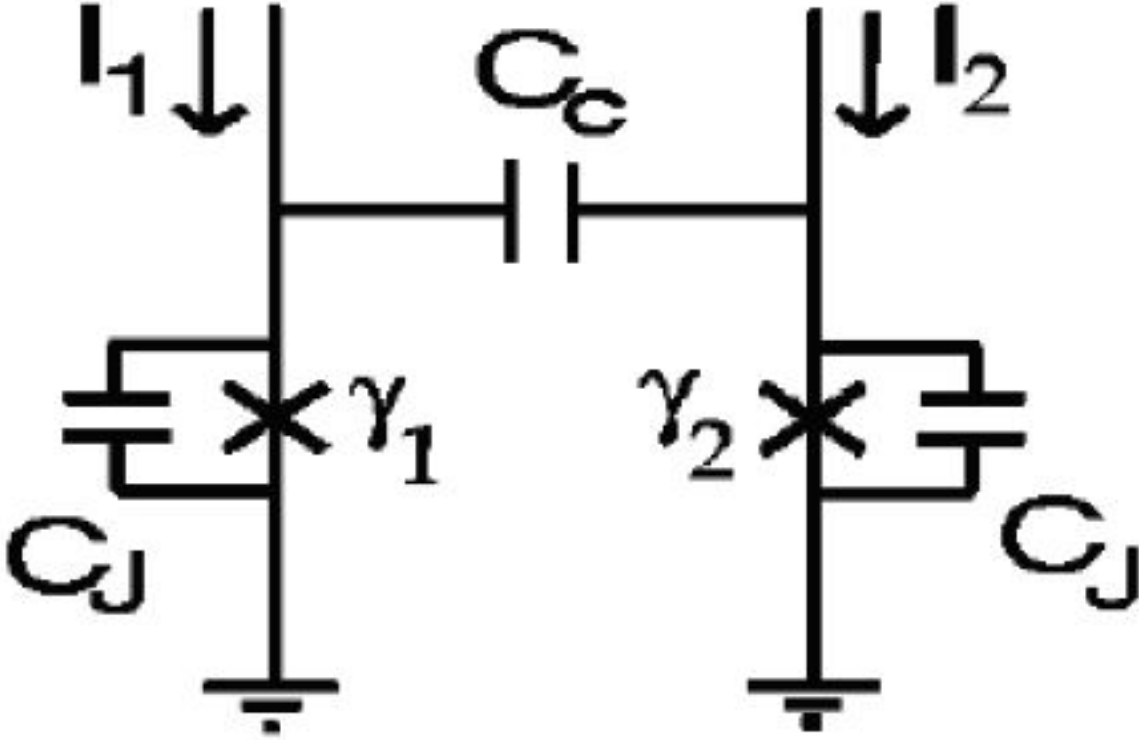

Figure 4: Coupled qubits.

For this system the Hamiltonian is

$$\begin{aligned}
 H = & \frac{\hat{Q}_1^2}{2C_J} - \frac{I_c \Phi_0}{2\pi} \cos \hat{\delta}_1 - \frac{I \Phi_0}{2\pi} \hat{\delta}_1 + \frac{\hat{Q}_2^2}{2C_J} - \frac{I_c \Phi_0}{2\pi} \cos \hat{\delta}_2 - \frac{I \Phi_0}{2\pi} \hat{\delta}_2 \\
 & + \frac{(\hat{Q}_1 - \hat{Q}_2)^2 C_c}{2C_J^2}.
 \end{aligned} \tag{18}$$

Therefore the coupling is of the form  $\hat{Q}_1 \hat{Q}_2$ . One can decouple the  $\hat{Q}$  part of the Hamiltonian by defining  $\hat{Q}_\pm \propto \hat{Q}_1 \pm \hat{Q}_2$ , and similarly for  $\hat{\delta}_\pm \propto \hat{\delta}_1 \pm \hat{\delta}_2$ . This gives

$$H = \frac{\hat{Q}_+^2}{2C_J} + \frac{\hat{Q}_-^2}{2C_J} + V(\hat{\delta}_+, \hat{\delta}_-). \tag{19}$$

In the symmetric case,  $I_{dc1} = I_{dc2}$ , the eigen states are the symmetric and antisymmetric combinations of the single junction states. The derivation for two-qubit operations is very similar to that of NRM quantum computer.